

# VACUUM HOSE REELS **V SERIES**

1 1/2" I.D.

**COXREELS® V Series** spring driven and hand crank vacuum hose reels are available in both vacuum only and vacuum/pneumatic combinations. Both are designed to extract unwanted fumes, particles and by-products from your work area. The vacuum/pneumatic models have dual plumbing for vacuum extraction while simultaneously powering pneumatic tools such as grinders and sanders in an enclosed efficient system.

## V SERIES

HOSE					LESS HOSE		SIZE INDEX
MODEL	DESCRIPTION	VACUUM			MODEL	APRX. LBS.	
		INLET	CAP.	HP			
<b>V100 SERIES</b>							
<b>V-117H-835</b>	Vacuum Only, Direct Crank	1 1/2" - 2" Cuff	35' of 1 1/2" Vac hose	Less than 5HP	35	-	<b>1</b>
<b>V-117H-850</b>	Vacuum Only, Direct Crank	1 1/2" - 2" Cuff	50' of 1 1/2" Vac hose	5HP or more	38	<b>V-117-850</b>	<b>30</b>

LESS HOSE							SIZE INDEX
MODEL	DESCRIPTION	VACUUM		AIR		APRX. LBS.	
		INLET	CAP.	INLET	CAP.		
<b>V1175 SERIES</b>							
<b>V-1175-850</b>	Vacuum Only, Direct Crank	1 1/2" NPT	50'	-	-	118	<b>2</b>
<b>V-1175-850-C</b>	Vacuum Only, Bevel Front Crank	1 1/2" NPT	50'	-	-	121	<b>3</b>
<b>V-1175-850-T</b>	Vacuum Only, Bevel Top Crank	1 1/2" NPT	50'	-	-	121	<b>3</b>
<b>VA-1175-850*</b>	Vacuum & Air, Rim Rewind	1 1/2" NPT	50'	1/2" NPT	50'	123	<b>4</b>
<b>VA-1175-850-C*</b>	Vacuum & Air, Bevel Front Crank	1 1/2" NPT	50'	1/2" NPT	50'	126	<b>4</b>
<b>VA-1175-850-T*</b>	Vacuum & Air, Bevel Top Crank	1 1/2" NPT	50'	1/2" NPT	50'	126	<b>4</b>
<b>V SERIES</b>							
<b>V-SLPL-825</b>	Vacuum Only, Spring Rewind	1 1/2" NPT	25'	-	-	102	<b>5</b>
<b>VA-DLPL-825*</b>	Vacuum & Air, Spring Rewind	1 1/2" NPT	25'	1/2" NPT	25'	107	<b>6</b>

\*VA models have dual plumbing for both vacuum & air applications, pneumatic swivel inlet is solid brass 1/2" NPT 300 PSI swivel

## REEL DIMENSIONS

Technical Data Sheets Available On Website

SIZE INDEX	W	H	L	X	Y	Ø	Dw
<b>1</b>	23 3/8"	18"	17"	15"	6"	6 3/4"	13 1/2"
<b>2</b>	24 7/8"	26 1/8"	24"	17 1/8"	20 1/4"	10 1/2"	11 5/8"
<b>3</b>	22"	26 1/8"	24"	17 1/8"	20 1/4"	10 1/2"	11 5/8"
<b>4</b>	21 3/4"	26 1/8"	24"	17 1/8"	20 1/4"	10 1/2"	11 5/8"
<b>5</b>	17 1/2"	24 1/2"	26 3/8"	15 3/8"	25"	10 1/2"	7 1/2"
<b>6</b>	20 1/8"	24 1/2"	26 3/8"	15 3/8"	25"	10 1/2"	7 1/2"

Overall Dimensions      Base      Drum

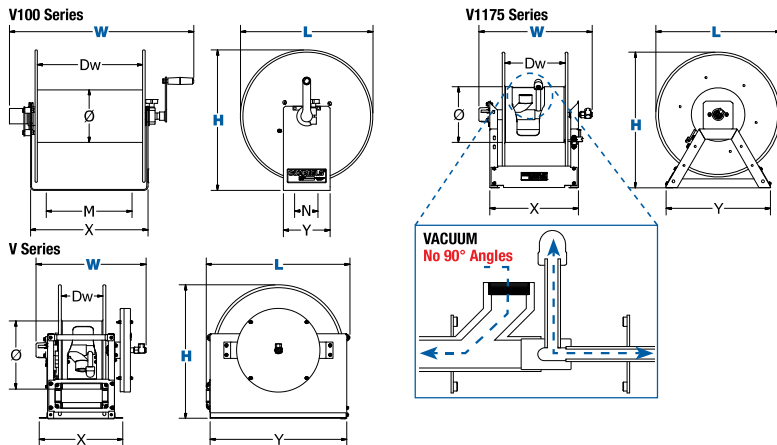

## V SERIES :: REEL SPECIFICATIONS

### V100 SERIES

- Direct hand crank reel with a solid one piece steel "U" shaped frame design
- Lightweight & compact design makes this reel the ideal solution for commercial vacuum systems
- Direct connect port for vacuum hose with bullet cuffs
- Adjustable tension brake to prevent "free-wheeling" during operation, transport or storage
- Swivel allows for the connection of 1 1/2" and 2" hose on the inlet.

### V1175 SERIES

- Sturdy all welded "A" frame base with a double supported steel axle
- Bevel gear hand crank (Removable handle for compact storage)
- Low profile outlet riser & open drum slot design, provide a non-crimping, flat smooth hose wrap

### V SERIES

- Enclosed factory tuned & matched cartridge-style spring motor
- Sturdy box-style frame with heavy duty steel cross supports to all four corners for extra rigidity
- Low profile outlet riser & open drum slot design, provide a non-crimping, flat smooth hose wrap
- Self-lubricated flange bearings & multi-position lock ratchet
- Lubricated factory matched cartridge-style spring motor
- Heavy duty 1" O.D non-corrosive stainless steel rollers
- Cast iron lock ring with non-sparking bronze pawl

### SIGNATURE FEATURES

- Professional grade heavy duty steel construction
- Durable proprietary CPC™ powder coat process
- Rolled edges & ribbed discs provide strength & safety
- Leading 2-year manufacturer's limited warranty
- Made in the U.S.A. - Sold & Supported Worldwide

### POSSIBLE FIELDS OF APPLICATION

- Vacuum Operation
- General Industrial
- Manufacturing Plants & Facilities
- Maintenance, Repair & Operations
- Construction Sites

### ACCESSORIZE YOUR REEL :: PG 52

- O-Rings & Swivels
- Roller Brackets
- Hoses
- Assorted Reel Accessories



WARNING: Cancer and reproductive Harm – See page 59 for more information – [www.P65Warning.ca.gov](http://www.P65Warning.ca.gov)

